



Since 1887
Over 100 Years of Service

Reeves-Wiedeman Company

PLUMBING SUPPLIES FOR CONTRACTORS AND INDUSTRY

SMALLPMP- Small Pumps RW List Prices - Page W-1

#1 Small Submersible Pump

Little Giant Oil-filled Submersible Pumps operate when completely submerged. Because they are hermetically sealed, motor windings can never become wet. All Die Cast Aluminum Pumps are covered with a corrosion resistant coating. Each is filled with a special oil that provides lifetime lubrication and rapid dissipation of heat through housing. Models shown are 115 volt. Contact factory for 230 volt availability.

- 1/150 HP; 1.1 Amps; 70 Watts; 3.2 PSI
- GPH: 1'=205; 3'=168; 4'=142; 5'=120; 6'=78; 7'=35
- Sump type pick up
- Smooth intake
- 1/4" male NPT discharge
- Polypropylene front and impeller
- Polyethylene screen
- 6', 3-conductor cord with 3-prong molded plug
- Epoxy coating



Little **GIANT**
Pump Company

Part #	Description	Price
27080001	501003 1 Submersible Pump	126.00

91250W Utility Pump

- Continuous duty, thermally protected-split capacitor motors, 1/4HP, 33.8 Amps
- Thermoplastic Construction
- 25 Ft vertical lift
- Garden hose adaptor included
- 1-1/4" or 3/4" Hose Discharge size
- 8' Cord
- Handles 1/8" Solids
- Fits into a 6" opening
- 1 Year Warranty



PERFORMANCE						
Model	Gallons per minute at listed discharge height					
	0'	5'	10'	15'	20'	25'
91250W	30	22	20	16	9	2



Part #	Description	Price
47000010	91250W Bubba 1/4 HP Utility Pump	138.00

5-MSP Water Wizard Utility Pump Makes water "VANISH" to within 1/8" of floor!

The Water Wizard is completely portable and easy use. Just attach a garden hose or 1" pipe, set into water at least 3/4" deep, and plug it in. Snap-off filter for easy cleaning. Equipped with 10' cord with 3-prong grounded plug. UL listed and garden hose adapter included free.

- 1/6 HP; 11.4 PSI
- GPH: 1'=1225; 5'=1150; 10'=960; 15'=780; 20'=480
- The most versatile portable utility pump removes water to within 1/8" off surface
- Cast aluminum housing with protective epoxy coating
- Available in 230 Volt Version



Little **GIANT**
Pump Company

Part #	Description	Price
27083856	505000 5MSP Portable Utility Pump	164.00

Reeves-Wiedeman Company

Emporia, Ks	Grandview, Mo	Independence, Mo	KCMO-Downtown	KCMO-Midtown	KCMO-Waldo	Lawrence, Ks	Junction City, Ks	Leavenworth, Ks
Liberty, Mo	Lees Summit, Mo	Lenexa, Ks	Manhattan, Ks	Maryville, Mo	Olathe, Ks	Riverside, Mo	Saint Joseph, Mo	Topeka, Ks

Shaded Items are Non-Stock

SMALLPMP- Small Pumps
Page W-2 - RW List Prices

PPS-1 Potent Pumps

- 115 VAC; 60 Hz
- GPH: 1'=275; 10'=225;
- Polypropylene pumping head
- Buna-N® impeller
- Polyacetal cam & SS shaft
- 3/8" FNPT & 3/4" garden hose intake & discharge
- Two 10' sections of garden hose with Water Eater accessory
- Thermally protected self priming pump
- 6' cord length
- UL Listed
- Component certified

Note: Potent Pumps are designed for intermittent use only (45 min, "on" - 15 min, "off") Do not run pump dry or at pumping heads greater than 35' (15 PSIG).



Little **GIANT**
Pump Company

Part #	Description	Price
27080300	555103 360-S Utility Pump	144.00

Liberty 331 Portable Transfer Pump

- Pump Housing is 1-piece, corrosion-resistant cast aluminum
- Impeller is glass reinforced thermoplastic with molded brass nut
- Ball Bearings are permanently lubricated, maintenance free
- 1/2 HP Motor, 115V AC, 8 amps, 60 HZ, 7500 RPM
- 20' heavy-duty power cord, with ground
- Height: 7" Width: 4½" Len: 9 3/4" Wgt: 10½ lbs.
- Maximum fluid temperature 135°F
- 3/4" Brass garden hose connection
- Use for water transfer, draining hot water tanks
- Boosts Water Pressure by 40 lbs.
- Not submersible



Liberty
Pumps

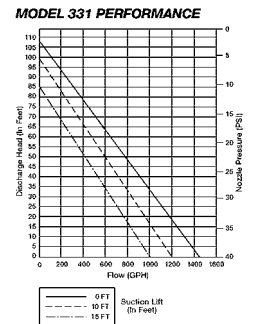

Part #	Description	Price
27060150	331 Liberty 1/2HP Portable Transfer Pump	334.00



Since 1887
Over 100 Years of Service

92333W Pedestal Pump

- 1/3 HP, 2.76 Amps
- 1-1/4 FNPT discharge
- Plastic base with 1-1/4" discharge will not rust
- Full adjustable automatic switch
- For use in sump basins 12" or larger
- Non-Corrosive steel drive shaft
- Metal switch arm
- 1 year warranty

PERFORMANCE						
Model	Gallons per minute at listed discharge height					
	0'	5'	10'	15'	20'	25'
92333W	50	45	38	35	15	0



BUBBA
PUMP

Part #	Description	Price
47000070	92333W Bubba 1/3 HP Pedestal Pump	150.00

VS-P Tall John Upright Sump Pump

- 1/3 HP; 115V-60Hz, 575 Watts
- Running Amps: 5.8
- PSI=7.4
- Handles small debris
- Plastic volute made of corrosion-proof polypropylene
- 1-1/4 FNPT discharge
- Automatic operation with integral Snap-Action float switch
- Adjustable on/off levels
- Thermal overload protection
- 8' Power cord
- GPM at Feet of Head=47GPM at 5', 34GPM at 10'
10GPM at 15', Shutoff at 17'
- Dimensions: 33 x 10.5 x 9.6; Wt=17.5Lbs



Little **GIANT**
Pump Company

Part #	Description	Price
27083865	547151 VS-P2800 Upright Sump Pump	164.00

SUMPPUMP- Sump Pumps
Page W-4 - RW List Prices

92250W Bubba Submersible Sump Pump

- 1/4 HP, 120V, 60Hz, 3.8 Amps
- Handles 1/8" Solids
- Turns on at 7", off at 4"
- 1-1/4 discharge
- Thermoplastic construction
- Continuous duty, thermally protected split capacitor motors
- Can be used as a utility pump by removing the float switch
- Tethered switch
- 8' Power cord
- 1 Year Warranty



Model	PERFORMANCE Gallons per minute at listed discharge height					
	0'	5'	10'	15'	20'	25'
92250W	30	22	20	16	9	2

Part #	Description	Price
47000020	92250W Bubba 1/4 HP Sump Pump	160.00

6-CIA Big John Submersible Sump Pump

- 3/10 HP; 720 Watts
- Starting Amps: 13; Running Amps: 9
- PSI=7.8
- No Solid Handling
- Submersible cast iron housing
- Polypropylene volute base
- Polycarbonate cover
- Lifetime oil supply
- Mechanical seals
- Diaphragm operated switch
- On Off levels of 7-10"/1-3"
- Non-clog pumping head & impeller
- Plastic screened intake
- 1½" discharge with 1¼" adaptor
- Motor with sleeve bearings & thermal overload protector
- 8' Cord with 3-prong plug & breather tube
- Convenient size fits 5 gallon bucket
- GPM at Feet of Head=45GPM at 5', 29GPM at 10'
13GPM at 15', Shutoff at 18'
- Dimensions: 6 x 9½ x 8½; Wt=18 Lbs

6-CIA-RFS with Piggy-Back Float Switch for Automatic Operation



6-CIA

Little **GIANT**
Pump Company



6-CIA-RFS

Part #	Description	Price
27083855	506174 6-CIA Sump Pump	220.00
27083875	506171 6-CIA-RFS Sump Pump	242.00



92342W Bubba Submersible Sump Pump

- 1/3 HP, 120V, 60Hz, 4.1 Amp
- Handles 1/8" Solids
- Turns on at 6", off at 4"
- 1-1/4" discharge
- Thermoplastic construction
- Continuous duty, thermally protected split capacitor motors
- Can be used as a utility pump by removing the float switch
- Vertical switch
- 8' Power cord
- 1 Year Warranty

BUBBA
PUMP



PERFORMANCE						
Model	Gallons per minute at listed discharge height					
	0'	5'	10'	15'	20'	25'
92342W	40	34	28	22	12	2

Part #	Description	Price
47000030	92342W Bubba 1/3 HP Sump Pump	218.00

6E-CIA-SFS Sump/Effluent Pump

- 1/3 HP; 620 Watts
- Starting Amps: 13; Running Amps: 8
- PSI=8.7
- Handles 1/2" solids
- 1½" discharge
- Integral snap-action float switch
- On/Off levels of 7"-10"/2"-5"
- Cast iron volute
- Nylon impeller
- Fully enclosed oil-filled cast iron motor housing
- GF polycarbonate cover
- GF polypropylene base
- Polypropylene float
- Thermally protected
- Mechanical seal
- GPM at Feet of Head=50GPM at 0', 33GPM at 5'
27GPM at 10', Shutoff at 20'
- Dimensions: 10¼ x 10½ x 8½; Wt=24.5Lbs



Little **GIANT**
Pump Company

Part #	Description	Price
27083857	506700 6E-CIA-SFS Sump Pump	254.00

SUMPPUMP- Sump Pumps
Page W-6 - RW List Prices

237 Liberty 1/3 HP Submersible Sump Pump

- 1/3 HP, 115 V, 60HZ, 3450 RPM 5.2 Amps
- 3/8" Solids Handling, vortex style impeller permits passage of solids without clogging.
- 1-1/2" Discharge
- Polypropylene and powder coated aluminum construction.
- Stainless steel rotor shaft.
- All fasteners – non-corrosive stainless steel.
- Max Fluid Temperature 140°F
- Oil-filled, hermetically sealed motors with thermal overload protection.
- Permanently lubricated upper and lower bearings.
- Unitized shaft seal.
- VMF Switch, magnetically operated for smaller pits down to 10" diameter
- Quick-disconnect 10' standard power cord allows replacement of cord in seconds without breaking seals to motor.
- Removable base allows suction down to 1/8"
- Two Year Warranty



Liberty Pumps

Part #	Description	Price
27060225	237 Liberty 1/3 HP Sump Pump	224.00

257 Liberty Sump Pump

- 1/3 HP, 115 V, 60HZ, 1725 RPM 5.2 AMPS
- 1/2" Solid Handling, Vortex Impeller
- 1-1/2" Discharge
- One Piece Cast Iron Motor, Epoxy Coated Housing (Uni-Body)
- Fasteners Stainless Steel
- Thermal Overload Protection, Oil Filled Motor
- Max Fluid Temperature 140°F
- Carbon And Ceramic Seal
- Ten Foot Power Cord, UL Approved
- Dimensions: 10.5" H, x 9.6" W, Wgt. 21#
- GPM at Feet of Head=44GPM at 5', 33GPM at 10'
15GPM at 15', Shutoff 18'
- VMF Automatic
- Two Year Warranty

PERFORMANCE CURVE

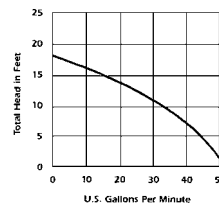

Liberty Pumps



Part #	Description	Price
27060000	257 Liberty 1/3 HP Sump Pump	232.00



Since 1887
Over 100 Years of Service

Reeves-Wiedeman Company

PLUMBING SUPPLIES FOR CONTRACTORS AND INDUSTRY

SUMPPUMP- Sump Pumps RW List Prices - Page W-7

8-CIA Big John Submersible Sump Pump

- 4/10 HP; 830 Watts
- Starting Amps: 14; Running Amps: 10
- PSI=9.9
- No Solid Handling
- Submersible cast iron housing
- Polypropylene volute base
- Polycarbonate cover
- Lifetime oil supply
- Mechanical seals
- Diaphragm operated switch
- On Off levels of 7-10"/1-3"
- Non-clog pumping head & impeller
- Plastic screened intake
- 1½" discharge with 1¼" adaptor
- Motor with sleeve bearings & thermal overload protector
- 10' Cord with 3-prong plug & breather tube
- GPM at Feet of Head=54GPM at 5', 42GPM at 10'
26GPM at 15', 8GPM at 20'
Shutoff at 22.9'
- Dimensions: 6 x 9½ x 8½; Wt=19 Lbs



Little GIANT
Pump Company

Part #	Description	Price
27083854	508157 8-CIA Sump Pump	348.00

92352W Bubba Submersible Sump Pump

- 4/10 HP, 120V, 60Hz, 7.6 Amp
- Handles 1/2" Solids
- Turns on at 9", off at 1"
- 1-1/2 discharge
- Cast iron construction
- Continuous duty, thermally protected split capacitor motors
- Can be used as a utility pump by removing the float
- Vertical switch
- 8' Power cord
- 3 Year Warranty



BUBBA
PUMP

Model	PERFORMANCE Gallons per minute at listed discharge height					
	0'	5'	10'	15'	20'	25'
92352W	60	56	50	35	15	6

Part #	Description	Price
47000040	92352W Bubba 4/10 HP CI Sump Pump	246.00

92511W Bubba Submersible Sump Pump

- 1/2 HP, 120V, 60Hz, 7.6 Amp
- Handles 1/2" Solids
- Turns on at 9", off at 1"
- 1-1/2 discharge
- Cast iron construction
- Continuous duty, thermally protected split capacitor motors
- Can be used as a utility pump by removing the float
- Vertical switch
- 8' Power cord
- 3 Year Warranty



BUBBA
PUMP

Model	PERFORMANCE Gallons per minute at listed discharge height					
	0'	5'	10'	15'	20'	25'
92551W	70	66	58	48	25	10

Part #	Description	Price
47000050	92511W Bubba 1/2 HP CI Sump Pump	312.00

Reeves-Wiedeman Company

Emporia, Ks	Grandview, Mo	Independence, Mo	KCMO-Downtown	KCMO-Midtown	KCMO-Waldo	Lawrence, Ks	Junction City, Ks	Leavenworth, Ks
Liberty, Mo	Lees Summit, Mo	Lenexa, Ks	Manhattan, Ks	Maryville, Mo	Olathe, Ks	Riverside, Mo	Saint Joseph, Mo	Topeka, Ks

Shaded Items are Non-Stock



TSW Self-Diagnostic Sump Pump

System includes: Pump with clear view cover, assy, and discharge kit with clear view check-valve

Pump

- 1/3 HP, 115 V, 475 Watts, 4.5 Amps
- Draws less than 5 full load amps
- 1-1/2" center discharge
- Engineered Thermo plastic housing, volute and impeller
- Vortex type impeller
- Nitrile with carbon and ceramic faces mechanical shaft seal
- Nitrile radial slip seal
- Stainless Steel fasteners
- 10' SJTW power cord
- 45GPM at 5', 40GPM at 10', 336 GPM at 15' shutoff at 33'
- Dimensions: 15x8.75x7.75. Wt: 13.8 lbs

Basin

- Polypropylene Basin
- Clear View ABS Cover
- 22" Basin = 22 gallons, 30" Basin = 30 Gallons
- 1-1/2" discharge
- 4" Adapta-A-Flex inlet

System

- Center discharge pump suspends from the cover to reduce the potential for clogging from gravel and other debris on the bottom of the basin.
- IntelliSwitch™ provides the most reliable automatic on/off operation and high water alarm activation
- IntelliPlug™ provides a red, high water alarm light and 85db buzzer, push to silence switch and green run light.



Little **GIANT**
Pump Company

Part #	Description	Price
27083900	507711 TSW-B22A Sump Pump Pkg	452.00
27083905	507713 TSW-B30A Sump Pump Pkg	474.00

SBX35 Liberty 1/3 HP SumpBox System

- Fully assembled
- 1/3 HP Pump
- Unique removable debris filter tray
- Large 41 Gal capacity
- Easy access cover requires no tools to open
- Easy to service float switches located in holders under access cover.
- Includes S35 Pump
- 18-3/4"x 24" W x 32" L
- 3 4" inlet hubs, 1-1/2 discharge and 2" vent



Liberty Pumps

Part #	Description	Price
27060160	SBx35 Liberty 1/3 HP Sumpbox System	634.00

FKIT441 Liberty 12V Battery Back-Up

- Designed specifically for the SumpBox
- Includes pump, piping, check valve, pre-set float switch, batter case and 4-state charger. (12 Volt marine-grade battery not included)
- Includes alarm feature



Liberty Pumps

Part #	Description	Price
27060165	FKIT441 Liberty 12V Battery Back-Up System	634.00

BUSUMP- Back-Up Sump Pump Systems
Page W-10 - RW List Prices

PHCC 1000 Standby Pump System

- Continuous-duty, submersible pump
- Pumps 1000 GPH at a 10 Ft Lift
- Trickle charger keeps the battery at full charge
- System controller continuously monitors the battery & power conditions to ensure dependable operation
- Stainless steel shaft, rulon seal and rust-proof housing provide long-lasting, reliable operation
- Sounds an alarm and indicates when:
 the AC power is out
 the circuit breaker has blown
 the battery fluid is low and water needs to be added
 the pump was activated
 the charger is charging the battery
 the battery is discharged, defective or the terminals need cleaning
- Battery & Z-Pack sold separately



Part #	Description	Price
37000200	PHCC-1000 Pro Series Standby Pump	280.00

Standby Battery for PHCC-1000



Part #	Description	Price
37000400	B-1000 Battery For PHCC-1000 Pump	168.00

Battery Acid Packs for PHCC Batteries

Part #	Description	Price
37000500	Z-Pack Battery Acid Pack	38.00

PHCC 1730 Standby Pump System

- Continuous-duty, submersible pump
- Pumps 1730 GPH at a 10-foot lift
- Stainless steel shaft, rulon seal, and rustproof housing provide long-lasting, reliable operation
- Computer programmed battery charging system
- Minimizes water loss in battery
- Ensures that the battery is always fully charged
- Computerized controller continuously monitors the pump, battery and power conditions to ensure dependable operation
- Sounds an alarm and indicates when:
 The battery fluid is low and water needs to be added
 The battery is discharged, defective, or terminals need cleaning
 The AC power is out or the circuit breaker has blown
 The pump was activated
 The safety fuse has blown
- Alarm can be silenced during an emergency and will automatically reset in 24 hours



Part #	Description	Price
37000050	PHCC-1730 Pro Series Standby Pump	524.00



BUSUMP- Back-Up Sump Pump Systems
RW List Prices - Page W-11

PHCC 2400 Standby Pump System

- Continuous-duty, submersible pump
- Pumps 2400 GPH at a 10 Ft Lift
- Fully automatic 13 amp charger
- System controller continuously monitors the battery & power conditions to ensure dependable operation
- Alarm can be silenced during emergency
- Stainless steel shaft, rulon seal, and rustproof housing provide long-lasting, reliable operation
- Can run dry without damage during the daily test procedure
- Runs pump when AC power is available without draining the battery
- Recharges quickly when the battery has been discharged
- Shuts off completely when the battery is fully charged to increase the life of the battery
- Tests the pump daily by running it 3 seconds
- Indicates the % of battery power available
- Sounds an alarm and indicates when:
 the battery fluid is low and water needs to be added
 the battery is discharged, defective or the terminals need cleaning, the AC power is out, the circuit breaker has blown, the pump is clogged or defective or the pump was activated.
- Battery & Z-Pack sold separately



Part #	Description	Price
37000120	PHCC-2400 Pro Series Standby Pump	958.00

APS-115 Auxiliary Power System

- In the event of a power outage, converts power from 12V DC batteries (not included) to 115V AC to Power Pumps up to 1/2 HP & 15 Amps with a service factor of 80%.
- Consists of Power Unit and Battery Enclosure.
- System Continually Monitors and Maintains Power to Batteries



Little **GIANT**
 Pump Company

Part #	Description	Price
27083880	513400 APS-115 Sure Sump Aux Pwr System	2982.00

Standby Battery for PHCC-2200/2400/1730



Part #	Description	Price
37000300	B-2200 Battery For PHCC-2400/2200/1730	254.00

BUSUMP- Back-Up Sump Pump Systems
Page W-12 - RW List Prices

SPBS-12 Battery Back-up Pump System



The SPBS-12 provides extra protection in the event the primary sump pump fails, an obstruction in the sump pit blocks flow, or a power outage occurs. The Little Giant back up sump pump system also functions as an alarm system if the primary pump fails to empty the sump pit. The back up system is powered by a 12 VDC battery (not included). The battery should be a deep cycle marine battery rated 105 to 140 amps-hours. A 140 amp-hour battery can provide in excess of 9 hours of continuous operation. A controller/charger monitors the battery condition and charges the battery when required. It also alerts the homeowner when the system has operated or when possible flooding conditions exist.

FEATURES

- 12 VDC Pump
- Audible Alarm
- GPH at head: 10'=1000
- Shut Off: 21'
- Controller/Charger/Alarm, 10 amp
When pump runs (must be reset)
- Float Switch When battery is discharged
- Check Valve for 12V pump
- Indicator Lights (LED) for:
- PVC Tee for connection to existing 1½" discharge
Power "ON" pipe of primary pump Battery Charging
- Battery Box (battery not included)
- Pump mounting bracket and clamps
- Primary Pump not included

Part #	Description	Price
27083870	506400 SPBS-12 Battery Backup Pump	598.00



Since 1887
Over 100 Years of Service

Reeves-Wiedeman Company

PLUMBING SUPPLIES FOR CONTRACTORS AND INDUSTRY

BUSUMP- Back-Up Sump Pump Systems
RW List Prices - Page W-13

Liberty SJ10 Back-Up SumpJet™ Sump Pump

- 1-1/4" Discharge
- 3/4" NPT Water Inlet Connection (optional hose connector included)
- Accepts 20PSI up to 100PSI inlet supply pressure*
- The SumpJet™ removes 2 gallons of sump water per 1 gallon used.
- Fully automatic, arrives completely assembled, and comes backed with Liberty's standard 2 year warranty.
- The SJ10 requires an uninterrupted water source to operate. If you have a well pump, the SJ10 will not operate during power outages.



Part #	Description	Price
27060185	SJ10 Liberty Water Powered Sump Pump	274.00

Liberty Backup SJ10A Sump Pump with Alarm

- 1-1/2 Discharge
- 3/4 NPT water inlet connection
- Accepts 20PSI up to 100PSI inlet supply pressure
- Removes 2 gallons of water for each 1 gallon used. (based on 5' lift)
- Fully automatic and fully-assembled
- Compact design
- High-output flow rates
- Works off municipal water supply
- UPC approved (IAPMO PS 119-2005)
- SHARKBITE® inlet connection accepts pex, copper or CTS CPVC 3/4" line



Part #	Description	Price
27060190	SJ10A Liberty Water Powered Sump Pump	492.00

Retro-Fit Alarm for SJ10

- Indoor alarm
- 115 Volt
- 9V battery back-up
- Compact probe mounted sensor (snaps on 1-1/4" or 1-1/2" discharge pipe)
- Auxiliary contacts
- Visual and audio alarm



Part #	Description	Price
27060195	ALM-P1 Liberty Retrofit Alarm For SJ10	190.00

Brick Platform for Submersible Sump Pumps

- A stable platform with pump locators designed exclusively to fit your Liberty submersible sump pump
- Raises the sump pump 2.5" off the bottom of your pit
- Reduces potential jamming from debris, rocks, mud, and sediments
- Durable ABS...will not corrode
- Replaces unstable blocks or bricks
- Fits exclusively Liberty Sump Pump Series: 230, 240, 250, 280, and S37.
- NEW! Adhesive tape adheres to pump base for ease of installation



Part #	Description	Price
27060200	4445000 Liberty Brick Pump Stand	18.00

Reeves-Wiedeman Company

Emporia, Ks	Grandview, Mo	Independence, Mo	KCMO-Downtown	KCMO-Midtown	KCMO-Waldo	Lawrence, Ks	Junction City, Ks	Leavenworth, Ks
Liberty, Mo	Lees Summit, Mo	Lenexa, Ks	Manhattan, Ks	Maryville, Mo	Olathe, Ks	Riverside, Mo	Saint Joseph, Mo	Topeka, Ks

Shaded Items are Non-Stock

SEWEJECT- Sewage Ejector Pumps
Page W-14 - RW List Prices

93501W Sewage Ejector Pump

Automatic Operation, Factory Set to Turn on at 14", off at 6" Water Level.

- 1/2 HP, 7.6 Amps, 120V
- Starting Amps: 15
- 2" Discharge
- Handles 2" solids
- Cast Iron construction
- Non clogging Vortex Impeller
- 8' Cord
- 1 Yr Warranty

BUBBA
PUMPS



PERFORMANCE						
Model	Gallons per minute at listed discharge height					
	0'	5'	10'	15'	20'	25'
93501W	80	68	60	44	13	2

Part #	Description	Price
47000060	93501W Bubba 1/2 Hp CI Sewage Pump	349.90

9S-CIA-RFS Sewage Ejector Pump
The Eliminator Series 2" Discharge

Automatic Operation. 11-16" on level range, 4-8" off level range with adjustable mercury float switch.

- 4/10 HP; 1020 Watts
- GPM at head: 5'=80; 10'=50
- Shut Off: 18'
- Starting Amps: 18; Running Amps: 12.5
- Handles liquids and 2" solids
- Cast iron pump housings with protective epoxy coating for corrosion and rust resistance
- Oil filled motor housings for lifetime lubrication and rapid heat dissipation
- Stainless steel screws, bolts, handle and seal assembly
- Mechanical seals (stainless steel spring, nitrile parts, carbon and ceramic faces)
- Thermal overload protection

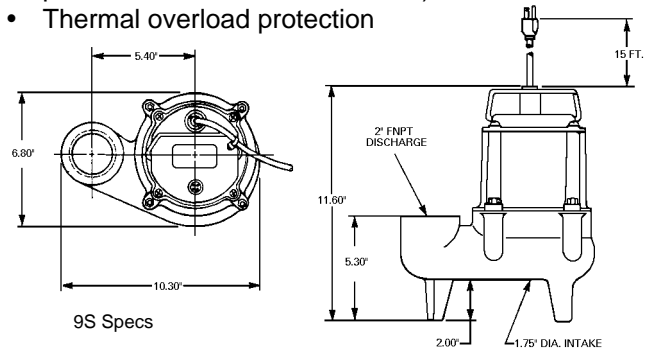

Little **GIANT**
Pump Company



Part #	Description	Price
27083853	509500 9S-CIA-RFS Sewage Pump	459.90



LE41A Sewage Pump

- 4/10HP , 1550 RPM, 12 Amps, 115 V
- 115 Volt Automatic Operation
- GPM at head: 6'=120; 10'=95; 18'=15
- Shut-Off at 19'
- 2" Discharge
- Handles liquids and 2" solids Cast Iron Motor Housing
- Thermal Overload Protection, Oil Filled Motor
- Max. Fluid Temperature 140°F
- Vortex Style Impeller
- Stainless Fasteners And Rotor Shaft
- 10' Power Cord, UL Approved, Quick Disconnect
- Dimensions: 14H X 10.75W, Wgt.= 39Lbs

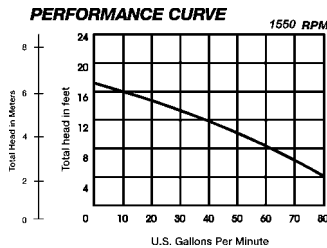

Part #	Description	Price
27060030	LE41A Liberty 4/10 HP Sewage Pump	479.90

LE51A Liberty Submersible Sewage Pump

- 1/2 HP; 1725 RPM, 13 Amps, 115 V
- GPM at head: 5'=135; 10'=110; 15'=80; 20'=40; 24'=5
- Shut-Off at 25'
- 2" Discharge
- Handles liquids and 2" solids
- Cast iron pump housing with protective coating for corrosion and rust resistance
- Oil Filled Thermally Protected Motor
- Permanently Lubricated Bearings
- Has an Adjustable Wide Angle Level Control with Series Plug.
- 2-Vane Corrosion Resistant Hytrel Impeller
- All Stainless Steel Fasteners and Rotor Shaft
- 10' UL Approved Quick Disconnect Power Cord

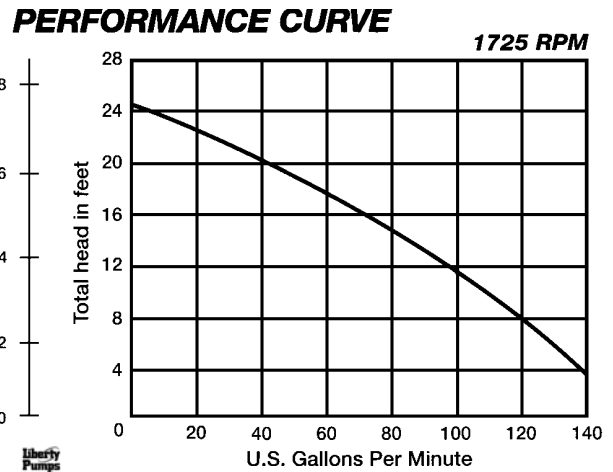

Part #	Description	Price
27060050	LE51A Liberty 1/2 HP Sewage Pump	549.90

SEWEJECT- Sewage Ejector Pumps
Page W-16 - RW List Prices

10S-CIA-SFS Sewage Ejector Pump
The Eliminator Series 2" Discharge

Automatic operation.

Has approximately 12" on level and 6" off level with integral snap-action mechanical float switch

- 1/2 HP; 1086 Watts
- GPM at head: 5'=110; 10'=85
- Shut Off: 20'
- Starting Amps: 17; Running Amps: 9.2
- Handles liquids and 2" solids
- Cast iron pump housings with protective epoxy coating for corrosion and rust resistance
- Oil filled motor housings for lifetime lubrication and rapid heat dissipation
- Stainless steel screws, bolts, handle and seal assembly
- Mechanical seals (stainless steel spring, nitrile parts, carbon and ceramic faces)
- Thermal overload protection

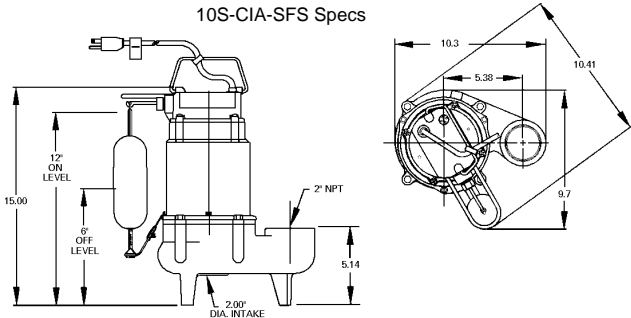

Little **GIANT**
 Pump Company

Part #	Description	Price
27080400	511550 10S-CIA-SFS Sewage Pump	639.90

LE71A2 Liberty Sewage Pump
2" Flanged Discharge

- 3/4 HP; 1725 RPM, 12 Amps, 115 V
- GPM at head: 5'=150; 10'=125; 15'=90; 20'=60; 25'=27 27'=5
- Handles liquids and 2" solids
- Cast iron pump housing and Volute with protective coating for corrosion and rust resistance
- Oil Filled Hermetically Sealed Motor
- Permanently Lubricated Upper Sleeve and Lower Ball Bearings
- Has an Adjustable Wide Angle Level Control with Series Plug.
- Rugged 2-Vane Semi-Open Cast Iron Impeller
- All Stainless Steel Fasteners and Rotor Shaft
- Unitized Shaft Seals
- Built-In Thermal Protection
- 10' UL Approved Quick Disconnect Power Cord

Liberty
 Pumps



PERFORMANCE CURVE

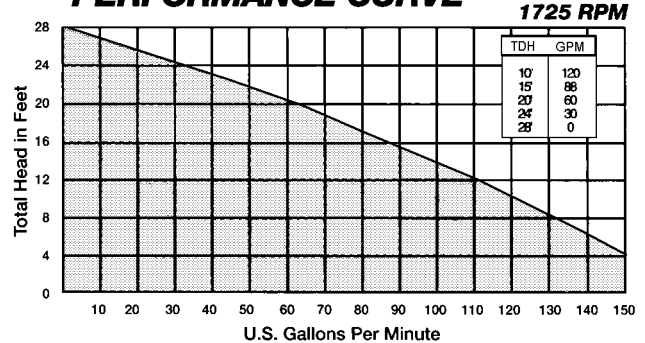

Part #	Description	Price
27060100	LE71A2 Liberty 3/4 HP Sewage Pump	849.90



16S-CIM Sewage Ejector Pump
The Eliminator Series 3" Discharge

- 1 HP, 1625 RPM, 230 volts, 1 phase, 11 Amps, 60 Hz
- Manual Operation
- GPM at head: 5'=180; 10'=150; 15'=130; 20'=100
 25'=70; 30'=35: Shut-off at 35'
- Handles liquids and 2" solids
- Cast iron pump housings with protective epoxy coating for corrosion and rust resistance
- Oil filled motor housings for lifetime lubrication and rapid heat dissipation
- Stainless steel screws, bolts, handle and seal assembly
- Mechanical seals (stainless steel spring, nitrile parts, carbon and ceramic faces)
- Permanent split capacitor design capacitor and power cord connection isolated from oil filled motor housing for ease of field maintenance.
- Dynamically balanced two-vane non-clog impeller with pump out vanes to keep solids away from seal for less seal and bearing wear.
- Thermal overload protection
- 20' Power cord



16S-CIM

Little **GIANT**
 Pump Company

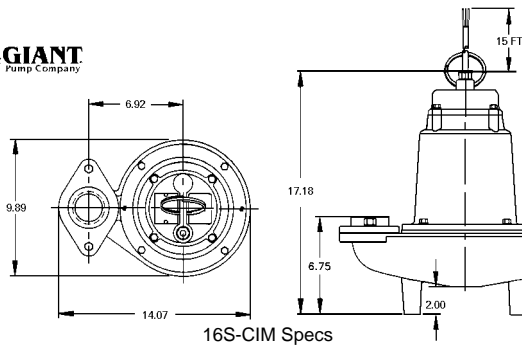

16S-CIM Specs

Part #	Description	Price
27080600	514620 16S-CIM Sewage Pump	1199.90

Little Giant Pump Company's origins date back to 1941, when an idea by a plumber named Doc Wolfe became the world's first submersible electric motor-driven pump - the answer to the problem of water transfer in "swamp" evaporative coolers, a forerunner of modern refrigerated air conditioning. Called "a submersible vaporizer," this unique, patented pump design became the cornerstone for the hundreds of different pump models Little Giant Pump Company manufactures and ships worldwide today.

In fact, derivatives of that basic "self-contained electric motor-driven submersible pump" have become the standard for quality and reliability in water transfer applications throughout the world.

Little Giant's strength has always been its mission: to solve problems with innovation, quality, reliability and cost-effectiveness. Every activity of the company, every piece of equipment, every innovation, is directed solely toward that end.

Little Giant Pump Company's comprehensive line now includes wastewater pumps, sump, effluent and sewage pumps, dewatering/trash pumps, condensate pumps, magnetic drive pumps, low pressure sewer systems, water garden pumps and products, and a wide variety of utility pumps.

PUMPACC- Pump Accessories
Page W-18 - RW List Prices

SF22A Jackel Basin Only for Sump Pumps

- Structural Foam Fiberglass
- 22 Gal Capacity
- 18x24 with SF22B blank cover
- Covers and Hubs Available

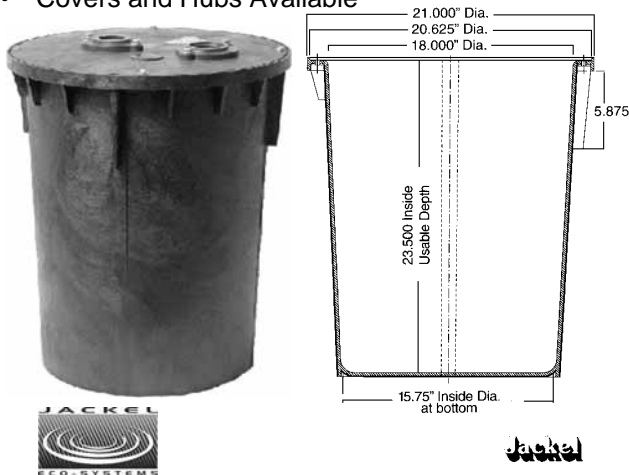

Part #	Description	Price
27090000	SF22A Jackel Sump Basin Only	71.50

Covers for Jackel SF22A

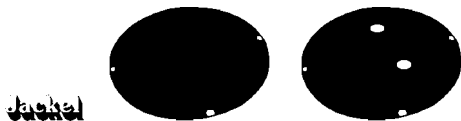

Part #	Description	Price
27099579	SF22B Jackel Cover Only For SF22A Basin	38.50
27090100	SF2000 Sewage 2 x 2 Cover	78.58

Hubs for Jackel SF22A

Part #	Description	Price
27090200	AAF400 4 Uniseal Hub	33.38
27099597	CIH4x24 Cast Iron Hub for SF24	77.18

SF30HS/GT Sewage Basin Only for Sewage Pumps

- Includes 4" snap-in hub
- The structural foam sewage ejector basin has a 30 Gal capacity (with FS114 2x2 split cover) to collect sewage and waste water for pump discharge to a septic tank or city sewer lines.

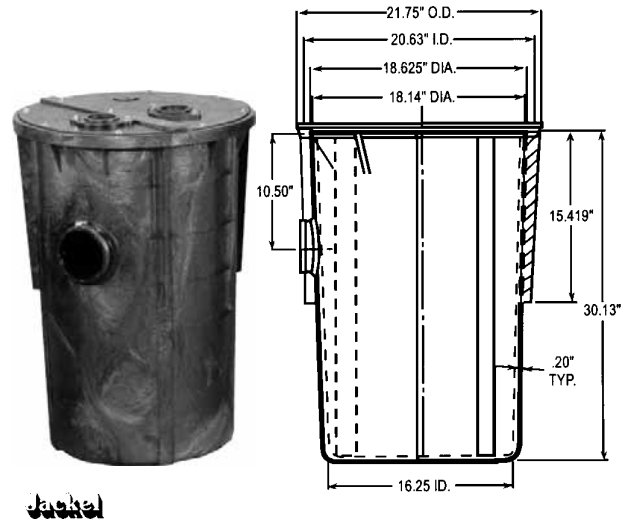

Part #	Description	Price
27090050	SF30HS/GT 18 x 30 Sewage Basin only	139.90

Cover for Jackel SF30

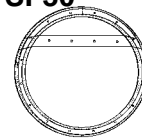

Part #	Description	Price
27099581	SFJ1793-114SF Split Cover Only (2 x 2)	78.58

Hub for Jackel SF30



Part #	Description	Price
27090300	SIH4 E400H 4 Hub For SF30 Basin	33.38



**SF24x36 Sewage Basin Only
for Duplex Sump Pumps**

- Structural foam ejector basin is a standard 24" x 36"
- 71Gal capacity basin with SF24 cover
- Collects sewage waste water for pump discharge to a septic tank or city sewer lines.
- Cover, with Inspection, and 4" Cast Iron Hub Available

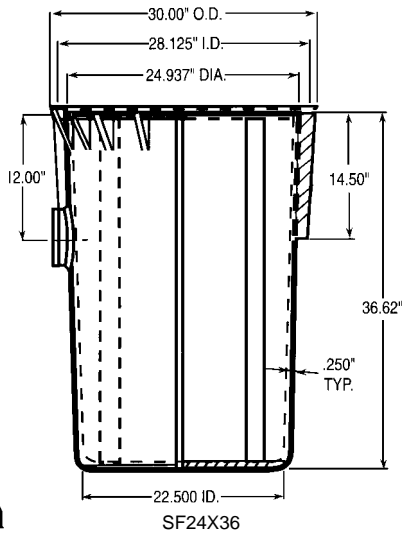

Part #	Description	Price
27099587	SF24x36 Jackel Sewage Basin Only	349.90

Cover for Jackel SF24

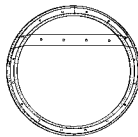

Part #	Description	Price
27099592	SF24SPLITBI Split Blank Cover	179.90

**RFSN-9 Wide Angle Float Switch
For use with Sump, Sewage and Effluent**

The float switch is a direct-acting, in-line control system for automatically controlling smaller pumps and sump pumps in water and sewage systems. The float switch consists of one float, a cord with a piggy-back plug, one large mounting strap, and two small adjustable mounting clamps.

- 115 VAC, 60 HZ Single Phase
Max starting amps: 40
Max running amps: 13
Max HP: 1/2
- 230 VAC, 60 HZ Single Phase
Max starting amps: 20
Max running amps: 13
Max HP: 1
- Totally self-contained pump switch
- No control panel required
- Directly controls pumps up to 1 HP (120V) or 2 HP (230V)
- Epoxy sealed switch and cord conductors are waterproof and weatherproof.
- Adjustable pumping range

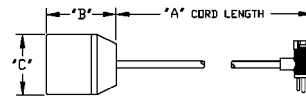

Dimensions: A=9' B=3.42 C=2.81

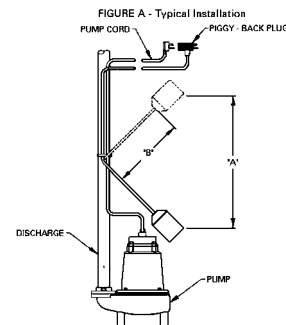

Part #	Description	Price
27083851	599117 RFSN-9 Float Switch	91.50

PUMPACC- Pump Accessories
Page W-20 - RW List Prices

Bubba Float Switches



Part #	Description	Price
47000100	92000 Bubba Pump Float Switch	61.78
47000110	92010 Bubba Pump Float Switch	72.50

Duplex Pump Alternator & Alarm System

- Low Cost Alternative to Conventional Duplex Control Panels
- Operates 2 automatic Pumps
- Pumps alternate every cycle every 20 seconds
- The 2nd Pump starts if the first fails
- Alarm sounds when water rises too high
- Pumps (not included) and float switch plug into unit, and unit plugs into wall outlet (no wiring)
- 115V, max 15 running Amps



Little **GIANT**
Pump Company

Part #	Description	Price
27083890	513325 HWD-115 Alternator / Alarm System	889.90

ALM-2 Liberty SumpBox Alarm

- Indoor/Outdoor type 3R
- 115V
- Red Beacon
- 82 db horn
- Test/Silence Switch



Liberty
Pumps

Part #	Description	Price
27060170	ALM-2 Liberty Sumpbox Alarm	169.90

Switch Repair for 6&8CIA

Little **GIANT**
Pump Company

Part #	Description	Price
27006508	599300 SPRK-1 Switch Repair Kit For 6&8CIA	49.10

Low Voltage High Water Alarm

- Remote sensor with 6' of wire detects water sounds alarm - will work up to 50' apart
- Powered by 9V battery (not included)
- 85-decibel alarm sounds for 3 days
- Low battery warning, Test Bar for system check



Little **GIANT**
Pump Company

Part #	Description	Price
27083885	513350 HW-9 Low Voltage Alarm	57.90



PUMPACC- Pump Accessories
RW List Prices - Page W-21

DJ545 Jackel Sump/Sewage Check Valve

- 1-1/4" or 1-1/2" pipe hose connection



Jackel

Part #	Description	Price
27099576	DJ545 Jackel 1-1/2 Check Valve	19.18

2GP Jackel Sump/Sewage Check Valve

- 2" x 2" pipe hose connection



Jackel

Part #	Description	Price
27099578	2GP Jackel 2 Check Valve	33.10

CH-150S-150MT Jackel 1-1/2 Check Valve

- 1-1/2" pipe hose connection x 1-1/2" NPTM threaded pipe connection.



Jackel

Part #	Description	Price
27099580	CH-150S-150MT Jackel 1-1/2 Check Valve	17.30

PVC Sewage Check Valve

- PVC Check valve uses compression gaskets to connect to IPS pipe.
- Full Flow Non-Clog Design
- Designed for Both Vertical and Horizontal Use.
- Suitable for Below Pit Cover Installation
- Can Be Used As A Union Connection



Little **GIANT** Pump Company

Part #	Description	Price
27008025	940019 CV-SE1 1-1/2 Sewage Check Valve	48.50
27008030	940022 CV-SE2 2 Sewage Check Valve	69.50

PVC Check Valve

- Spring Loaded



B & K

Part #	Description	Price
03348298	101-607 B&K 1-1/2 SW PVC Check Valve	14.58

Heavy Duty Compression Fit Check Valves

- Heavy-duty PVC
- 125 PSI rated
- Vertical or horizontal installation
- 140° F maximum fluid temperature
- For use with sump or sewage pump



Liberty Pumps

Part #	Description	Price
27060205	1-1/2 CV2N1C Liberty Comp PVC Check Valve	31.70
27060210	2 CV200C Liberty Comp PVC Check Valve	52.38

Quiet Spring Loaded Check Valves

- Heavy Duty PVC
- Spring-loaded valve reduces "water hammer" effect
- 125 PSI rated
- Vertical or horizontal installation
- Maximum fluid temp. 160 degrees F
- For use with sump or sewage pump



Liberty Pumps

Part #	Description	Price
27060215	1-1/2 QCV150 Liberty PVC Quiet Check Valve	52.38
27060220	2 QCV200 Liberty PVC Quiet Check Valve	62.90

WRSYS- Water Removal Systems
Page W-22 - RW List Prices

WRS-6 Drinosaur Water Removal Systems

APPLICATIONS: The Drinosaur removes water from laundry trays, lav sinks, wet bar sinks, or dehumidifiers, air conditioners (condensate), water softeners, etc. where gravity drainage is impractical. Installs above floor, no need to dig a sump.

BASIN: Made of polypropylene for durability, light weight, and corrosion resistance. Basin fluid capacity is 5.0 gallons.

BASIN COVER: Polypropylene cover has a 1½" FIP FIP intake, 1½" FIP discharge, 2" FIP vent and a cord exit hole. A rubber grommet designed to fit the cord exit hole is provided. The cover also comes either a removable filter screen for easy cleaning. The filter cover and and basic cover are designed with o-rings to provide a water-tight seal.

- GPH at Head: 5'=2750; 10'=1750; 15'=720
- Starting Amps: 13; Running Amps: 9
- Shut Off: 18'
- PSI=7.8
- 3/10 HP automatic submersible sump pump with 8' power cord & 3 prong grounded plug
- Preassembled IAMPO Approved Basins
- Dimensions: 13.88 x 15.56



Little **GIANT** Pump Company

Part #	Description	Price
27083859	506055 WRS-6 Drinosaur Pump	369.90

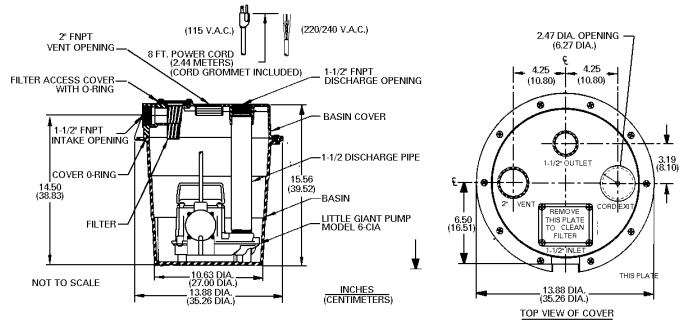

Drinosaur & Compact Drinosaur Specs

WRSC-6 Compact Drinosaur
Same features as the Drinosaur except:

- Compact 3.5 gallon tank - Only 10½" high
- Automatic submersible pump with mid-level activating switch
- Dimensions: 13.88 x 10.50

Little **GIANT** Pump Company



Part #	Description	Price
27083860	506065 WRSC-6 Drinosaur Pump	369.90



Liberty Commercial Water Removal System

- 1/2HP Pump
- Use for Hot Water up to 180°

APPLICATIONS: Bar sinks, laundry trays, multi-compartment utility sinks, dehumidifiers, dishwashers and gray wastewater drainage below gravity lines

Specifically designed for higher head applications such as commercial and industrial buildings.

- GPH at Head: 5'=2700; 10'=1740; 15'=720
- 1/2 HP automatic submersible sump pump with 10' power cord & grounded plug
- 3/8" Solids-Handling
- QuickTree™ technology allows quick inspection and removal of float switch without disconnecting the plumbing.
- 3450 RPM. Oil filled, Thermally Protected
- Corrosion-resistant polyolefin basin with integrally molded rubber gasket for a superior gas-tight seal.
- Maintenance-free, permanently lubricated sealed bearings.
- Shut-off - 34', maximum flow of 48 GPM @ 5 feet of total dynamic head
- Factory pre-assembled.
- Dimensions: 14-1/8 x 13-3/4
- Handles fluid
- Not intended



**Liberty
Pumps**

Part #	Description	Price
27060230	405 1/2 HP Commercial Drain Pump	509.90

405 Performance Curve

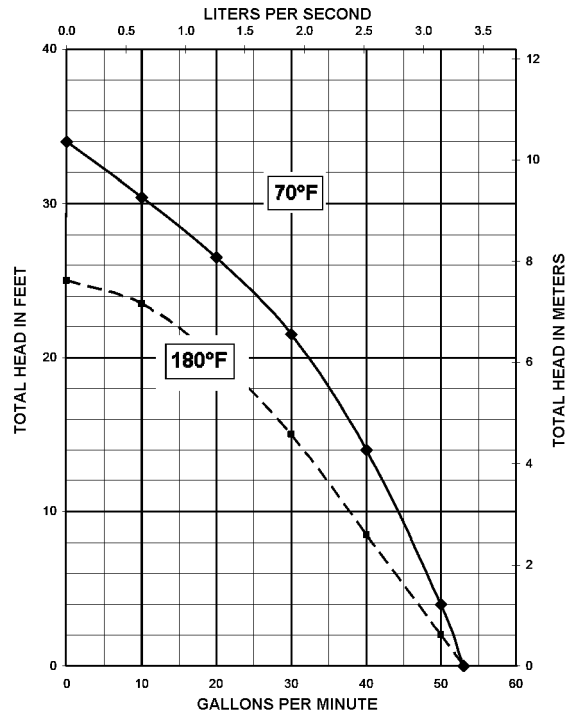

SEWEJSYS- Sewage Ejector Systems
Page W-24 - RW List Prices

9S-SMPX Simplex Package Systems
Sewage & Effluent

Little Giants 9S-SMPX sewage & effluent package systems contain an 9S-CIA-RFS Eliminator Series pump w/non-mercury float switch BS-1830-CS-2V-2D, polyethylene basin (PN: 113030), basin inlet hub cover assembly (PN: 113045), and check valve (PN: 940022). The gas tight covers are complete with vent and discharge flanges, cord seals, gasketing, & hardware.

- 2" Discharge pipe handles up to 2" solids
- 2" Vent pipe
- 2-Hole cord seal
- Basin not prepunched for Vinyl Hub (to be installed by end user)
- Capacity for a typical single family dwelling installation:
 - 5' V lift for 650' H distance
 - 6' V lift for 550' H distance
 - 7' V lift for 500' H distance
 - 8' V lift for 400' H distance
 - 9' V lift for 350' H distance
 - 10' V lift for 250' H distance
 - 11' V lift for 200' H distance
 - 12' V lift for 100' H distance



Little **GIANT**
 Pump Company

Part #	Description	Price
27080605	509091 9S-SMPX-LG Sewage Pump Package	669.90

P382LE51 Liberty 1/2 HP Sewage Ejector

- QuickTree™ float system allows easy removal of floats without pulling the pump.
- Shallow 24" basin for easier burial in difficult soil conditions
- Large 41 Gal capacity
- Anti-Flotation collar
- Molded torque-stops
- Integrally molded handles
- Unique integrated cord seal technology
- Integral rubber cover seals
- Clear disposable cover protects the system during masonry work and rough-in.
- Includes LE51A Pump

Liberty
 Pumps



Part #	Description	Price
27060175	P382LE51 Liberty 1/2 HP Sewage Ejector	1429.90